

**INSTRUCTION MANUAL**  
**MODEL MM-2**  
**MULTIPHASE RF ANALYZER**

*Central Electronics, Inc.*  
*1247 W. Belmont Ave.*  
*Chicago 13, Ill.*

MULTIPHASE RF ANALYZER  
MODEL MM-2

INSTRUCTION MANUAL

132MX

CENTRAL ELECTRONICS, INC.  
1247 BELMONT AVE.  
CHICAGO 13, ILL.

## MODEL MM-2 RF ANALYZER

The Multiphase Model MM-2 RF Analyzer is a compact 3" oscilloscope with self-contained 1000 cycle audio oscillator. It has been functionally engineered for maximum convenience in analyzing transmitter RF systems and IF envelope patterns of received signals. A versatile instrument for design, service or continuous monitoring applications.

### GENERAL INSTRUCTIONS

The MM-2 is shipped from the factory ready to operate. Connect to any convenient 115 volt 50-60 cycle outlet. It is suggested that you familiarize yourself with the following controls before placing unit in service. They are listed below in the proper sequence of operation.

OFF - ON - 1KC

Turns on AC power in mid-position. Turns on 1000 cycle pure tone in the 1KC position. Constants are chosen for least distortion, therefore actual frequency may vary between 1000 and 1300 cycles. This frequency variation does not adversely affect the alignment of SSB generators.

#### FUNCTION

Selects mode of operation; MAN provides a recurrent base line for TRANSMIT ENVELOPE patterns with sweep synchronized to 1KC oscillator.

NOTE: IF NO RM RECEIVING ADAPTER IS USED ALL OTHER POSITIONS OF THE FUNCTION SWITCH WILL REQUIRE RF TO OBTAIN A PATTERN. WHEN AN RM RECEIVING ADAPTER IS INSTALLED ALL OTHER POSITIONS OF THE FUNCTION SWITCH WILL DISPLAY THE RECEIVER IF ENVELOPE SIGNAL UNTIL RF IS APPLIED FROM YOUR TRANSMITTER.

The SINE position is also synchronized with the 1KC oscillator. The SPEECH position syncs the saw tooth sweep with the external AF INPUT for easier observation of voice waveforms. The AF TRAPEZOID position requires an audio connection to the modulator of an SSB or AM transmitter. In the RF TRAPEZOID position, the RF output of the exciter and linear amplifier must be connected through the MM-2.

#### INTENSITY

Increase clockwise until a line appears.

#### POSITION CONTROLS L-R and U-D

Adjust for left-right and up-down to center base line on cathode ray tube.

#### HORIZONTAL SIZE

Adjust to fill screen. Functions only on MANUAL or during TRANSMIT

## FOCUS

There may be some interaction between the Focus and Intensity controls. Adjust for best focus consistent with brightness desired.

## SWEEP

Adjust for desired ENVELOPE pattern.

## CAUTION!!

Sustained brilliant patterns will burn or discolor the phosphor in the cathode ray tube.

TO AVOID ANNOYING ELECTRICAL SHOCK FROM AC LINE BY-PASS CAPACITORS, DISCONNECT THE MM-2 POWER CORD BEFORE MAKING CABLE CONNECTIONS.

### CONNECTIONS FOR TRANSMIT ENVELOPE PATTERNS

Simply connect the RF output of the transmitter through the HIGH LEVEL coax connectors on the rear of the chassis to the antenna

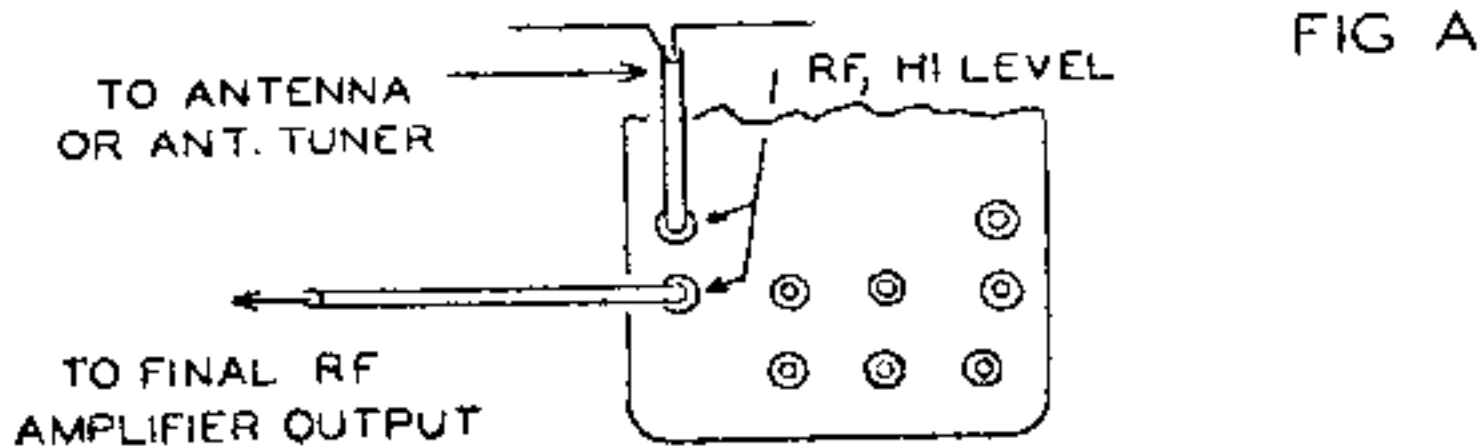

It is best to make the cable between the MM-2 and the transmitter as short as possible. In essence the RF output is fed right through the MM-2 to the antenna. No tuning is required throughout the frequency range of 1 to 55 MC. A small portion of the signal is sampled and fed to the vertical plates of the cathode ray tube. The VERTICAL SIZE is controlled by an RF attenuator calibrated in 3 db. steps. It should be set to 21 db. for 10-20A Multiphase Exciters and to about 12 db. for a Multiphase 600L. Avoid position 21 for power outputs in excess of 250 watts.

### ALTERNATE RF PICKUP CONNECTION

If other than coaxial cable is used a pickup antenna is necessary, or a coax coupled pickup link placed near the final RF amplifier plate coil. With open wire or ribbon feed systems, a length of wire in close proximity to one of the feeders is recommended.

### CONNECTIONS FOR TRANSMIT CW ENVELOPE PATTERNS

Use same RF connections as for SPEECH ENVELOPE Patterns. The keying or sweep speed should be varied until the pattern locks. An automatic key is recommended. The SPEECH position on the FUNCTION switch should be used for best patterns.

### CONNECTIONS FOR TRANSMIT SINE ENVELOPE PATTERNS

In addition to the RF connections for SPEECH ENVELOPE patterns it is necessary to connect the output of the 1KC audio oscillator to the audio input of the transmitter.

FIG B

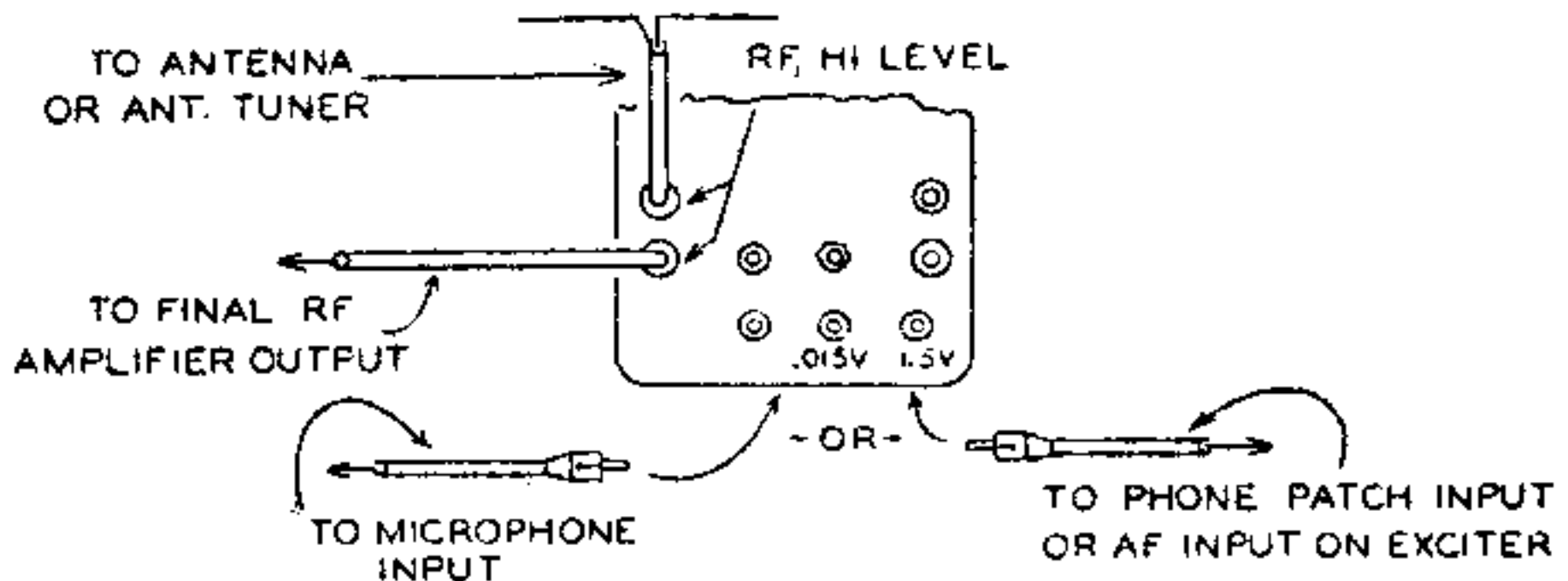

Two output levels are provided; .015 volts for use in the microphone connector and 1.5 volts for use in phone patch or phono input jacks. Use a shielded audio cable. Connectors are furnished to go between the MM-2 and the AF INPUT or Phone Patch Jack on the 10B and 20A Multiphase Exciters - plugging in disconnects the microphone circuit.

NOTE: The 1KC output from the 1.5 volt jack on the MM-2 is intended to feed into an impedance of 50,000 ohms or higher. Since the phone patch input on a KWS-1 is about 680 ohms, it is necessary to use the .015 volt connection to prevent excessive loading on the 1KC oscillator. As a further convenience the output of the 1KC oscillator is controlled by the Power ON - 1KC Switch. This allows the cables to remain connected and the tone to be applied by the switch on the MM-2.

You will note during the alignment of phasing type SSB exciter that carrier leakage will show a given number of ripples on the envelope pattern, while unwanted sideband will show twice that number.

CONNECTIONS FOR TRANSMIT AF TRAPEZOID OR BOW TIE PATTERNS

In addition to the RF and AF connections required for SINE Envelope patterns, it is necessary to obtain a sample of the transmitter audio signal appearing at the point where the audio modulates the RF.

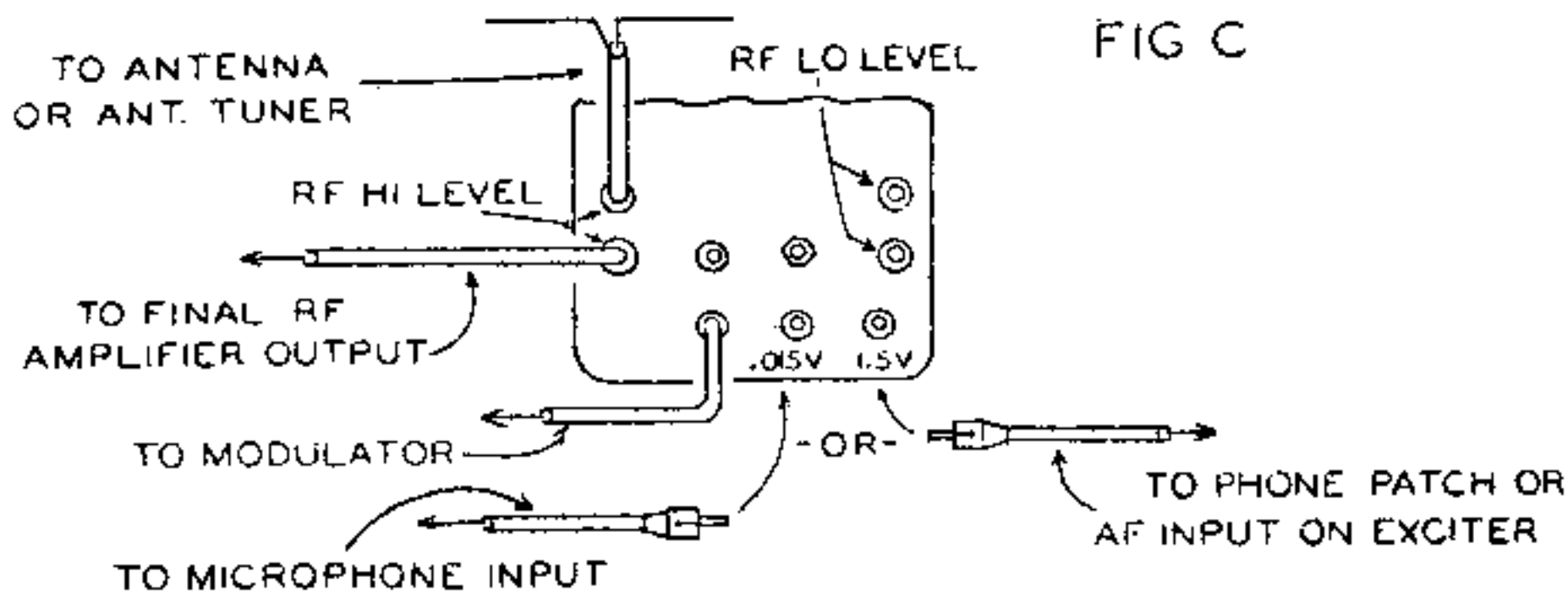

This point may be the secondary of a low voltage, low impedance transformer, as in the 10-20A Multiphase Exciters. Mount a phono connector on the rear of the chassis. Add a lead from connector to the RED lead on the Modulation Switch. This phono jack has been installed on 10B and 20A Exciters where the letter "C" follows the serial number.

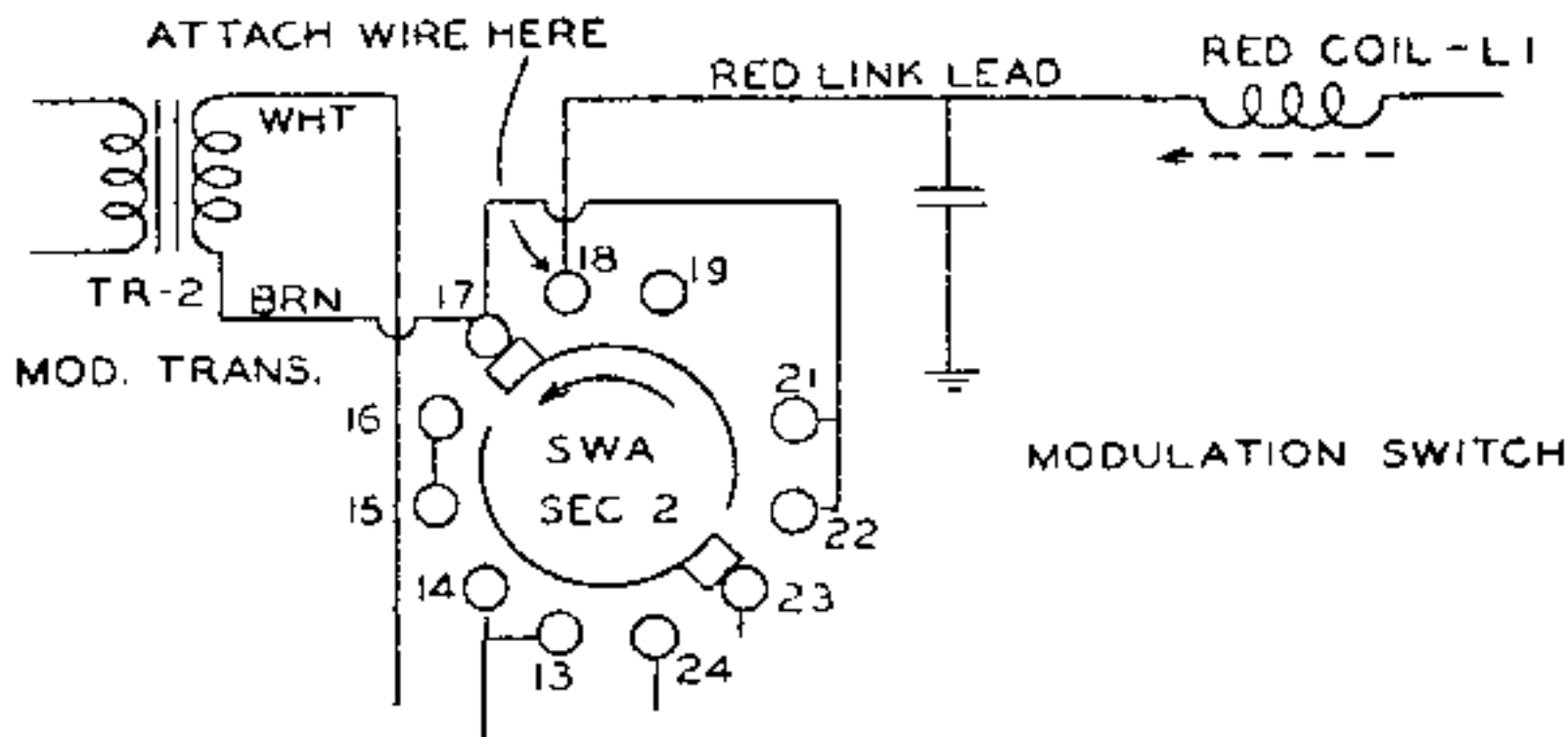

The audio sampling point might be a high voltage winding also carrying DC, as in the case of a plate or screen modulator for an AM transmitter. Where the voltage exceeds about 100 volts, a voltage divider will have to be used. Add another 100K 2 watt resistor in series with R1 for each additional 350 plate volts.

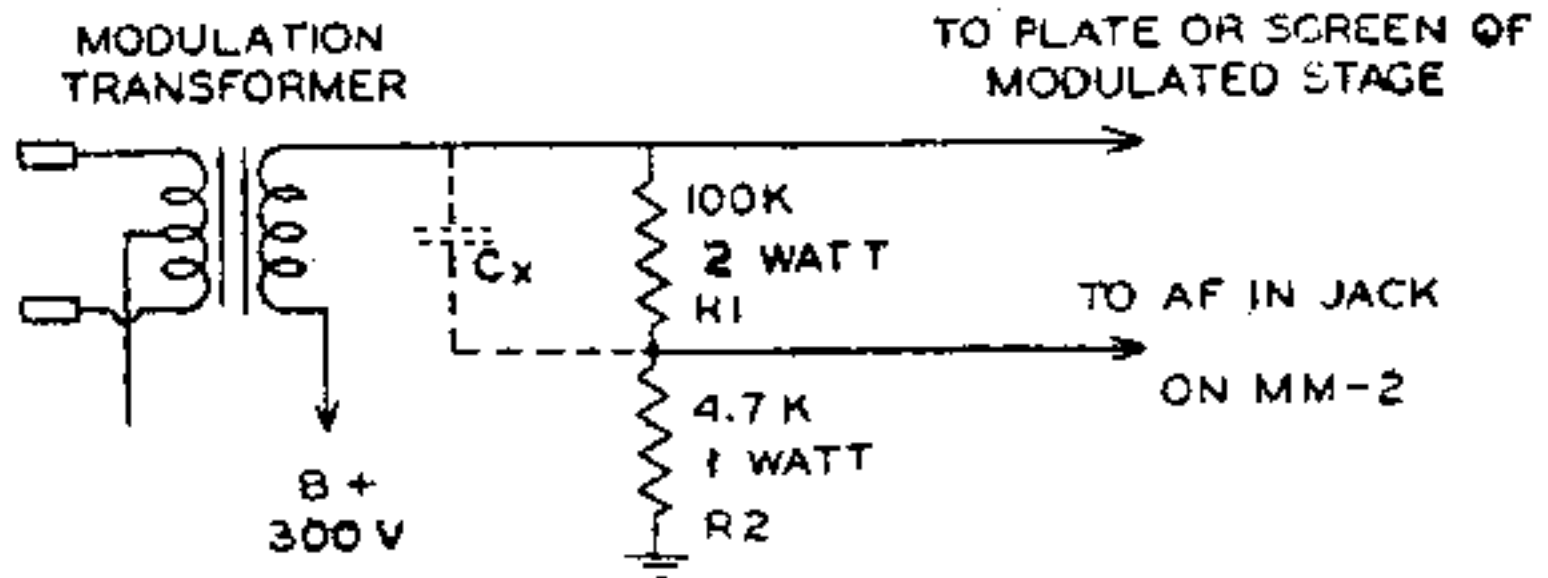

$C_x$  may be required to correct for audio phase shift and should be a high voltage capacitor.

In systems where the modulating signal is less than 5 volts at high impedance, such as the grid of a receiving tube, the use of a cathode follower is recommended.

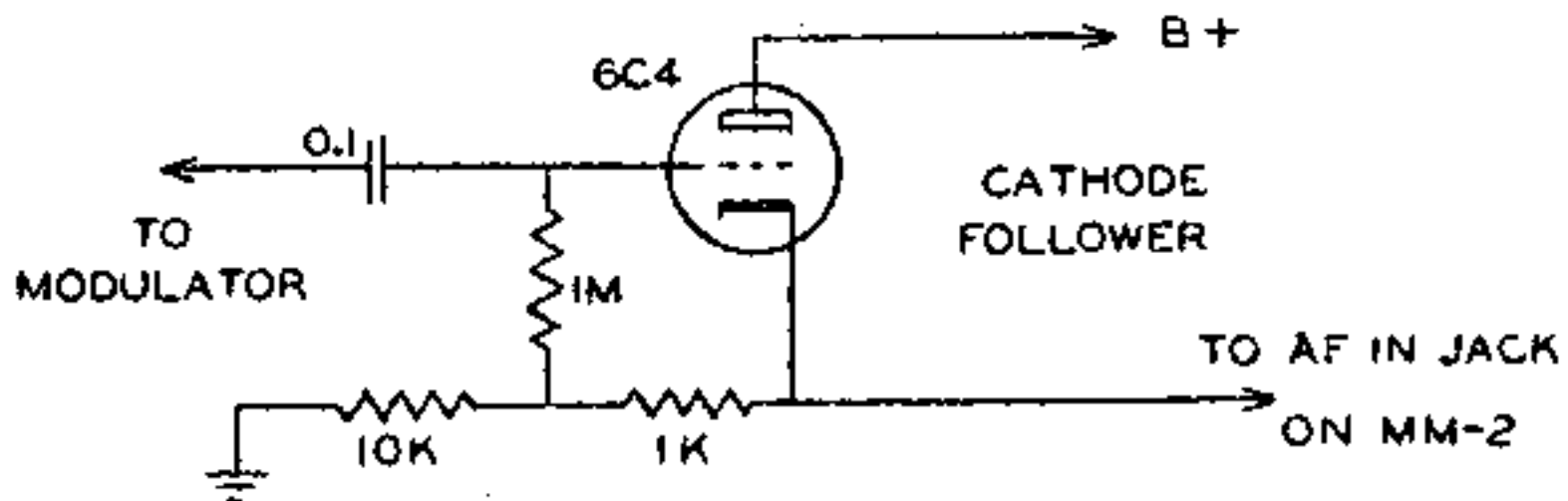

The sampled audio modulating signal obtained, as outlined above, is connected to the AF INPUT on the MM-2. Shielded cable is recommended. This signal is applied through the horizontal amplifier stage to the horizontal deflection plates of the cathode ray tube. To obtain a trapezoid pattern, an RF signal containing one sideband with carrier, or two sidebands with carrier (AM) must be applied to MM-2 as shown on Fig. C.

To obtain a BOW TIE Pattern an RF signal with two sidebands and no carrier should be applied to the MM-2. On 10-20A Multiphase Exciters, a convenient way to obtain this pattern is to set the modulation selector to AM and balance out the carrier.

#### CONNECTIONS FOR TRANSMIT RF TRAPEZOID PATTERNS

This function is intended for evaluation of the "Linearity" of an RF amplifier stage. In addition to the connections required for SINE ENVELOPE it is necessary to connect the RF output of the exciter through the LOW LEVEL coax connectors to the input of the linear amplifier.

FIG D

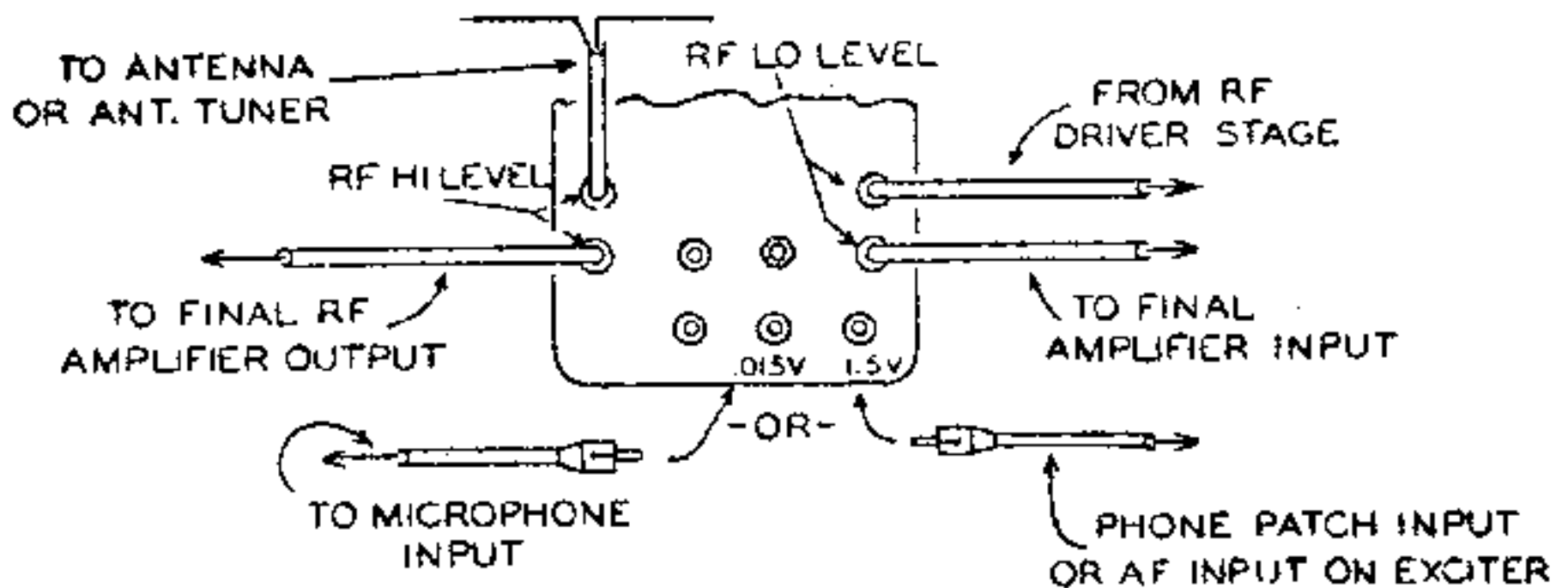

To obtain an RF Trapezoid pattern it is necessary to drive the linear amplifier with two sidebands and no carrier (DSSC = double sideband suppressed carrier), one sideband with carrier, or two sidebands with carrier (AM). On all Multiphase Exciters the AM position will furnish two sidebands with or without carrier. On filter type SSB exciters, one sideband and carrier will be required. The 1KC audio oscillator should furnish the modulating signal for the exciter.

The trapezoid pattern is obtained by comparing the RF output signal on the vertical plates to the demodulated RF input signal applied to the horizontal plates. The horizontal amplifier stage provides sufficient size from low power exciters. Do not apply more than 100 watts of RF power through the LOW LEVEL RF Input. If the driver stage is capable of power output in excess of this value, the RF energy for the LOW LEVEL Input should be sampled through a small variable capacitor and a T connector.

**IMPORTANT!** The RF trapezoid pattern indicates the linearity of the final amplifier only. It should NOT be used for general monitoring since it does not evaluate the operation of the exciter. The Low Level RF connections should be removed when other patterns with extreme accuracy are desired.



## CONNECTION TO THE RECEIVER

To monitor the IF ENVELOPE of a received signal, it is necessary to remove the MM-2 cabinet and install an RM adapter with the same frequency as the last IF in your receiver. The adapters are available for IF frequencies of 450 to 500 KC (RM-455), 80 KC (RM-80) and 50 KC (RM-50). The RM-80 may also be used for 60KC IF systems.

The RM adapter plugs into an octal socket near the rear of the chassis. Two screws secure the adapter. Unplug the .01 disc capacitor on the picture tube socket and plug into the lead on top of the adapter IF can. See Fig. F.

The accessory bag contains the IF cable for the receiver connection with a series 15 mmf capacitor attached to two slipover tube pin connectors. Locate the last IF amplifier tube in the receiver. This is the tube that amplifies the IF signal just before detection. Unplug the tube and determine the control grid pin from the table on Fig. E. Install the proper slipover connector on the tube pin, fold back unused connector and plug tube back in socket. Ground the cable shield wire to the nearest convenient point on the chassis. Slip IF cable through any convenient hole or slot in the cabinet and plug into IF INPUT jack on the rear of the MM-2. After the slipover connector has been installed, it may be necessary to retune the secondary of the IF transformer in the receiver for maximum output.

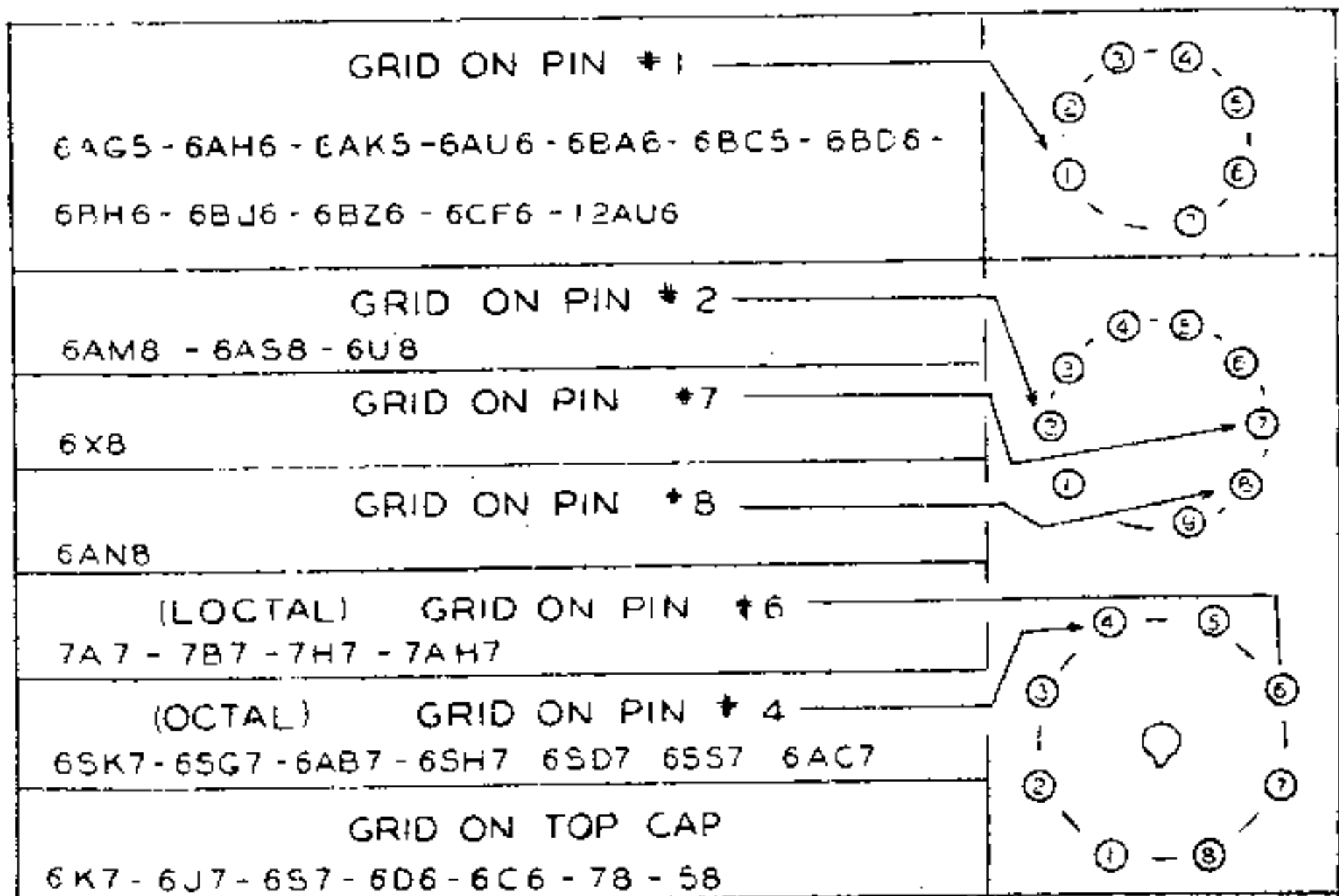
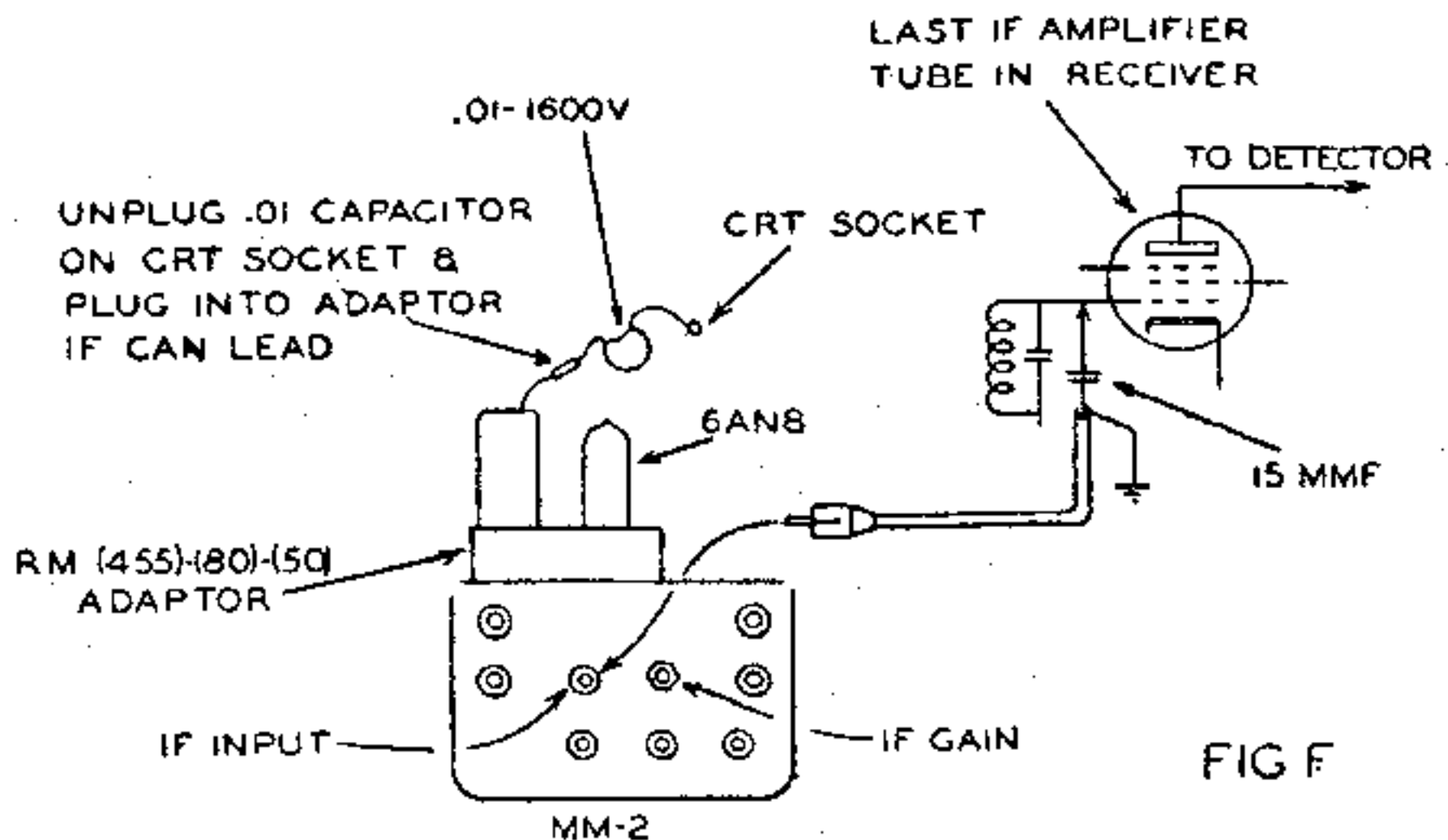

FIG E



INSTALLATION OF RM ADAPTOR

If the height of the received pattern is too small, it may be necessary to increase the value of the coupling capacitor to the grid of the last IF amplifier from 15 mfd. to 50 mfd. The input coaxial cable should be kept as short as possible.

#### CONNECTION FOR THE COLLINS 75A4 RECEIVER

When the IF input cable is connected to the plate of the last IF amplifier tube, the BFO in most receivers will give a large CW pattern on the MM-2 at all times. When this connection is used on the 75A4, the CW pattern is only about 1/2" high and is not too objectionable. Most 75A4 owners prefer the plate connection (to pin #5) due to the larger pattern obtained.

#### CATHODE RAY TUBE STATIC CHARGE DISTORTION

Under certain conditions, especially during periods of low humidity, it is possible for static electricity to accumulate on the face of the cathode ray tube. This will seriously "warp" or "stretch" a portion of the pattern, and result in some very unusual displays. When this exists, the face of the cathode ray tube should be washed with Tide or other similar detergent.

When your transmitter is on standby, the IF ENVELOPE pattern of the received signal is displayed, unless FUNCTION Switch is on MANUAL. Tune in a continuous carrier, such as your VFO or XTAL Calibrator. Advance the IF GAIN control on the rear of the MM-2 fully clockwise and peak the trimmers on the IF can of the RM adapter for maximum PEK height. Reduce the receiver RF gain or the signal level to keep pattern approximately 2" high. This prevents misalignment due to overload in the receiver.

#### RECEIVE ENVELOPE PATTERNS

The MM-2 IF GAIN should be adjusted to produce a pattern about 2" high from an average strength signal with the receiver adjusted for normal operation.

The AVC systems in some receivers may distort the IF ENVELOPE picture, so accurate reports should be given with the AVC OFF and Receiver RF gain adjusted to give a pattern approximately 2" high.

The IF bandwidth of the receiver will determine its ability to pass in true display an overmodulated or square topped signal. See Fig. G. In order to reproduce a square wave it is necessary to have IF bandwidth of at least ten times the modulating frequency. A receiver with 3 KC bandwidth will allow modulated RF from a 300 cycle square wave to be displayed on the MM-2; however, 1000 cycle square wave modulation will be displayed as a SINE WAVE. Therefore, SSB signals that are "flat topped" at the transmitter may look acceptable on the RECEIVE ENVELOPE pattern. As the receiver bandwidth is increased to 16 KC the ability to perceive "flat topping" improves as shown in Fig. G.

A "flat topped" signal can be segregated by observing the lack of peaks and valleys in the IF ENVELOPE pattern. See Fig. G. All syllables appear to reach a constant height. It is also possible that a signal may be deliberately "flat topped" by using premodulation clipping. Premodulation clipping and filtering may be used in a transmitter without increasing its bandwidth if the following RF system is operated below its "flat topping" point.

FIG. G



CLEAN SIGNAL (SSB)  
NO INTERFERENCE

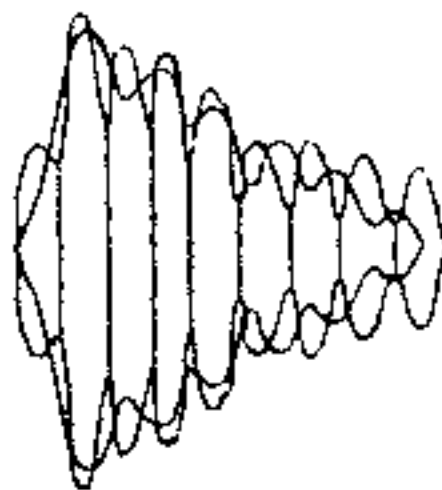

HETERODYNE  
INTERFERENCE

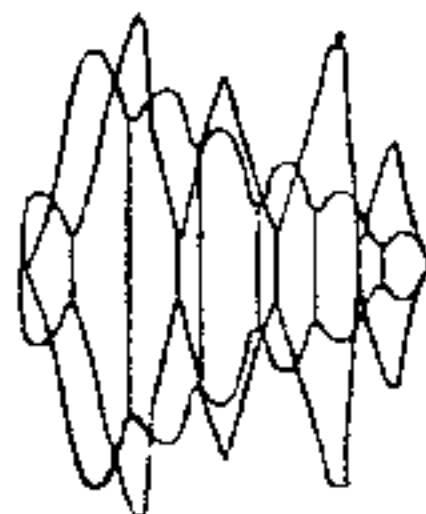











































SSB INTERFERENCE

CONTINUED ON PAGE 8A

FIG. G CONTINUED.

MM-2 RCVE PATTERNS

SIGNAL AT XMTR		RECEIVER BANDWIDTH				
		3 KC	4 KC	6 KC	10 KC	16 KC
	TWO TONE 1000 $\mu$ NO FLAT TOPPING					
	1000 $\mu$ MILD FLAT TOPPING					
	1000 $\mu$ SEVERE FLAT TOPPING					
	300 $\mu$ NO FLAT TOPPING					
	300 $\mu$ MILD FLAT TOPPING					
	300 $\mu$ SEVERE FLAT TOPPING					
	SSB SPEECH (MALE VOICE) NO FLAT TOPPING		NOTE REDUCTION OF SHARP PEAKS ON 3 KC BANDWIDTH			
	SEVERE FLAT TOPPING		NOTE VALLEY DOES NOT GO INTO BASE LINE RINGING IN RCVR IF SYS- TEM CAUSES IRREGULAR- ITIES			

ENVELOPE PATTERNS

Pure CW Carrier



E1

CW Carrier with spurious radiation 10 db. down.

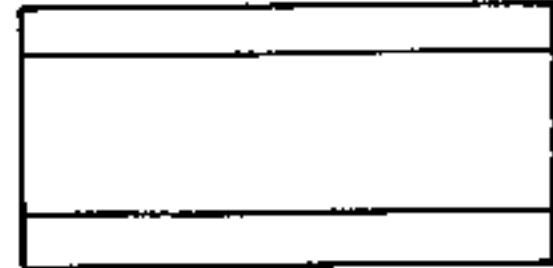

E2

CW Carrier with spurious radiation about 20 db. down.

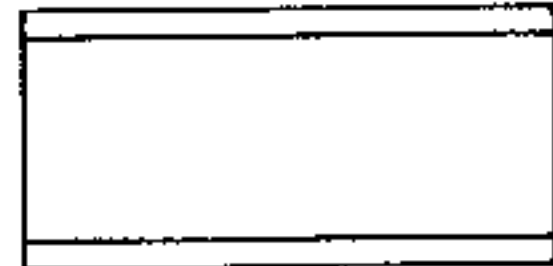

E3

SSB signal, voice input, correctly adjusted.



E4

SSB signal, voice input, slightly excessive speech gain, or insufficient amplifier loading.



E5

SSB signal, voice input, badly overmodulated.

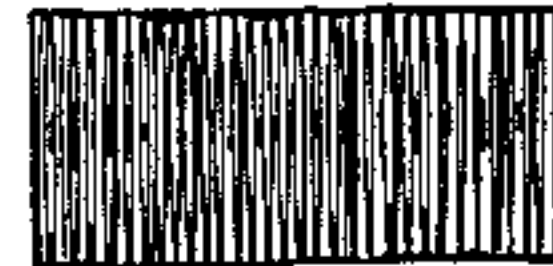

E6

SSB signal, tone input, sideband suppression approximately 40 db.

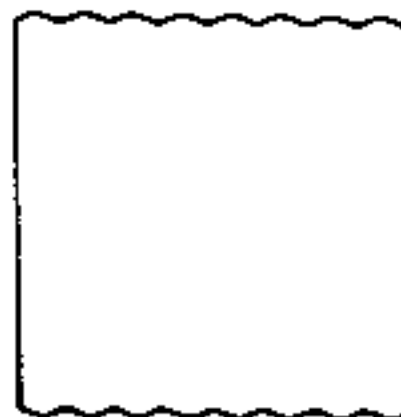

E7

Same as above. Sideband suppression 35 db.

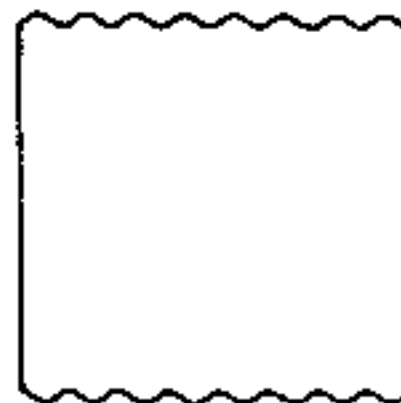

E8

Same as above. Sideband suppression 30 db.

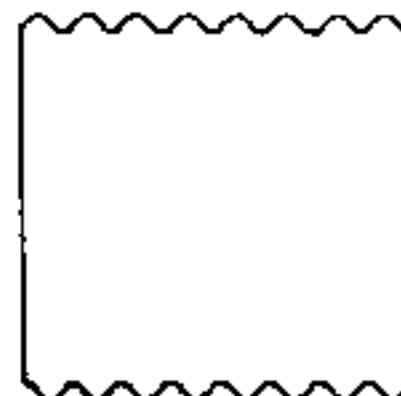

E9

Same as above. Sideband suppression 25 db.

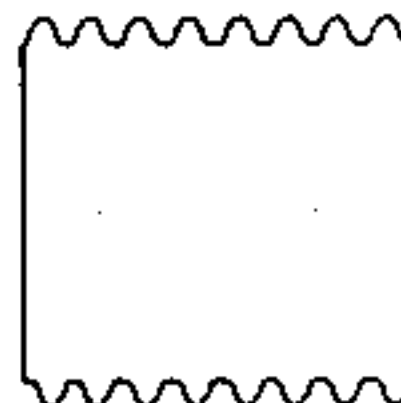

E10

Same as above. Sideband suppression 20 db.

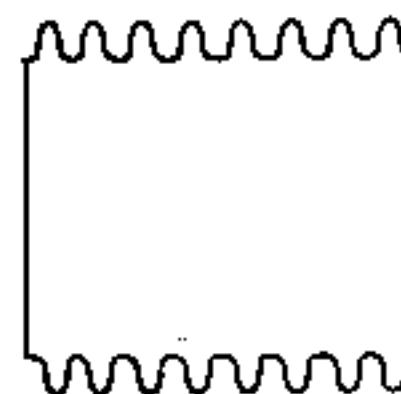

E11

SSB signal, tone input. Poor suppression. May be due to audio unbalance, or RF phase shift is not  $90^\circ$ .



SSB signal, tone input. Carrier leakage. Note this pattern has half the number of ripples as the pattern above.

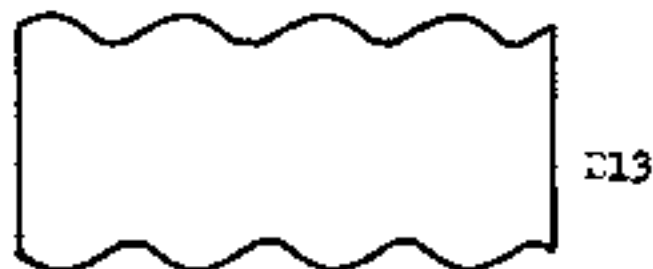

SSB signal, tone input. Spurious radiation about 20 db. down.



SSB signal, tone input. Spurious radiation about 10 db. down.

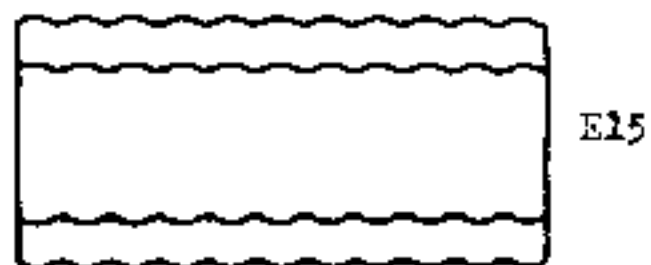

SSB signal, tone input. Distortion in audio oscillator or audio system.



SSB signal, tone input. Balanced modulator detuned, or insufficient RF in balanced modulator



SSB signal, tone input. Very little sideband suppression. Caused by defective modulator tube; audio phase shift network; 90° AF phase shift component; partially shorted modulation transformer; secondary of transformer that feeds audio phase shift network shorted to ground; master crystal oscillating on two adjacent frequencies simultaneously. On Multiphase Models 10 and 20 Exciters, L2 seriously misaligned.

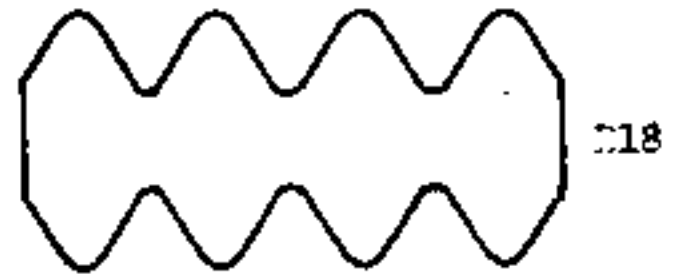

SSB signal, tone input. No sideband suppression. One modulator tube dead; modulation transformer open or shorted.

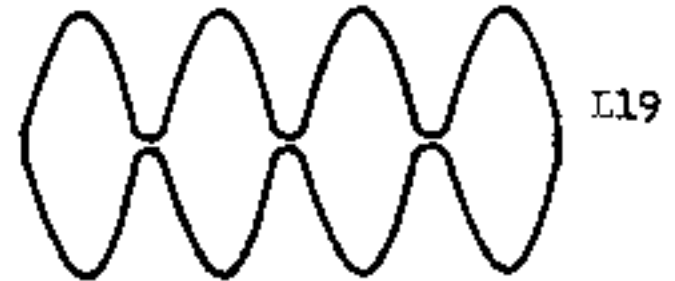

SSB signal, tone input. Amplifier flattening due to excessive RF drive. Note lack of fine ripple on the envelope.



Double sideband without carrier, or single sideband with carrier 100% modulated, tone input. This may be used for a "Two Tone Test." Excellent waveform.



SSB with carrier, tone input. Incorrect value of carrier or modulation.



Plate modulated AM, or double sideband with carrier inserted, tone input. 100% modulated. Excellent waveform.





Double sideband with carrier inserted (low level AM), tone input. Overmodulated, too much audio gain.



E24

Double sideband with carrier inserted (low level AM), tone input. Too much carrier inserted. Note that the positive peaks flatten before a fine base line is obtained.



E25

Double sideband with carrier inserted (low level AM), tone input. Insufficient carrier insertion, resulting in high distortion. Also called Double Sideband Reduced Carrier (DSRC).

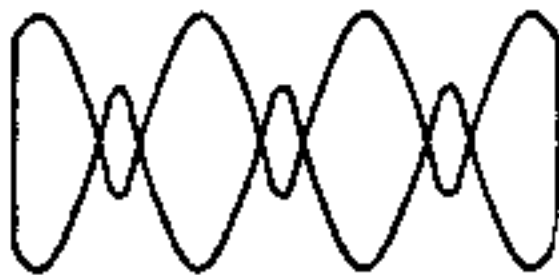

E26

Low or high level AM. Extremely strong positive peak parasitics.

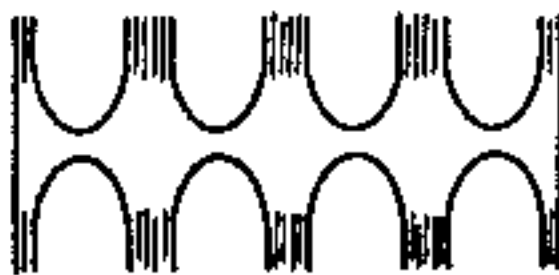

E27

Low or high level AM. Strong positive peak VHF parasitics.



E28

Low or high level AM. Mild fundamental frequency parasitics.



E29

Double sideband without carrier, tone input. Carrier leakage through working modulator. In Multiphase Models 10 and 20 Exciters, carrier null potentiometer "A" unbalanced.



E30

Double sideband without carrier, tone input. Carrier leakage through disabled modulator. In Multiphase Models 10 and 20 Exciters, carrier null potentiometer "B" unbalanced.



E31

Double sideband without carrier, tone input. Peaks flattened due to excessive AF or RF drive, insufficient interstage loading, or insufficient antenna coupling.



E32

Low or high level AM, tone input. Severe distortion in modulator system or AF tone generator. RF feedback to audio system, or RF feedback to previous low level stage.



E33

Nonlinearity in modulated RF stage, due to insufficient excitation of a plate modulated stage or overdrive to a grid modulated stage. Insufficient antenna loading of a grid modulated stage.



E34

Plate modulated AM, tone input. Insufficient modulator output. Modulation in excess of 100% in downward direction.



E35

Plate modulated AM, tone input.  
Modulator output more than ample.  
Modulation in excess of 100% in  
both directions

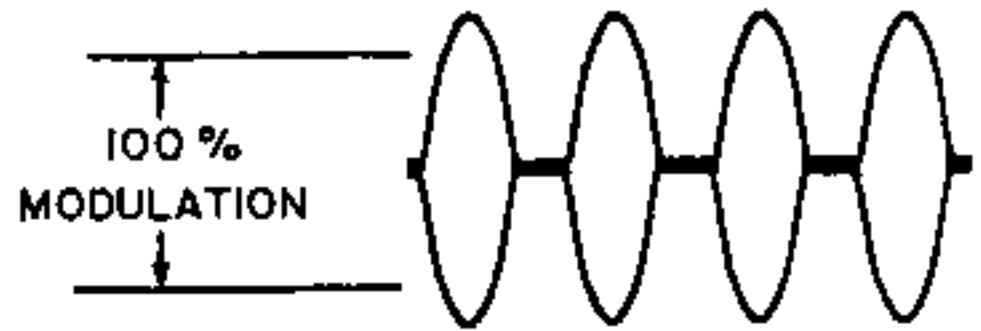

E36

DOUBLE TRAPEZOID OR BOW TIE PATTERNS

These require connection as shown in Figure C. They may be obtained by applying two audio tones simultaneously (or one audio tone plus carrier) to a SSB exciter, or a single tone to a phasing type exciter in the AM position with the carrier balanced out.

Good linearity. Desired pattern.

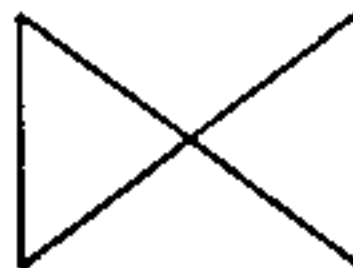

B1

Peaks slightly flattened. Caused by overdrive or insufficient antenna loading.

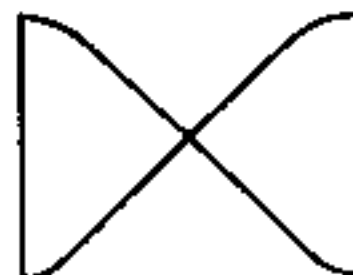

B2

Peaks severely flattened, due to overdrive.



B3

Carrier leakage through working modulator. On Models 10 and 20 Exciters, carrier null potentiometer "A" unbalanced.



B4

Carrier leakage through disabled modulator. On Models 10 and 20 Exciters, carrier null potentiometer "B" unbalanced.



B5

Grid current curvature. Note the slight departure from linearity at the point where the tube draws grid current.

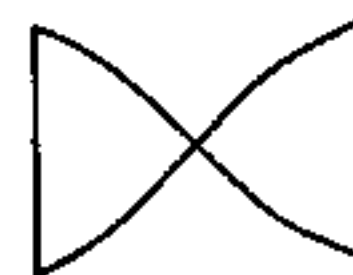

B6

Grid bias curvature. Caused by excessive bias, or by operating some types of tubes with high plate voltage and high bias. May also be due to regeneration, or imperfect neutralization.



B7

Extreme grid bias curvature. Same as above.



B8

Non linearity due to overdrive, or by excessive degeneration.

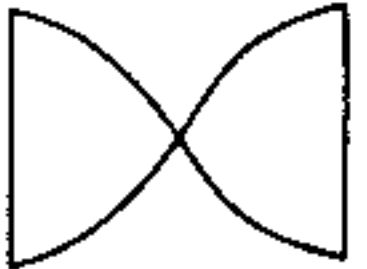

B9

Spurious radiation about 20 db. down. Insufficient selectivity in RF circuits, allowing undesirable beat products to pass through.

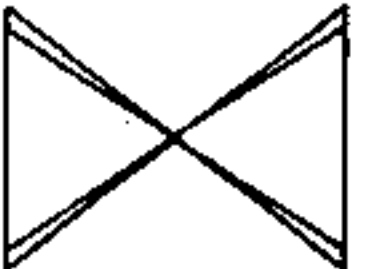

B10

Parasitic oscillation.



B11

Severe parasitic oscillation.



B12

TRAPEZOID PATTERNS

Plate modulation, single or double sideband with carrier, or RF trapezoid. Good linearity. Desirable pattern.

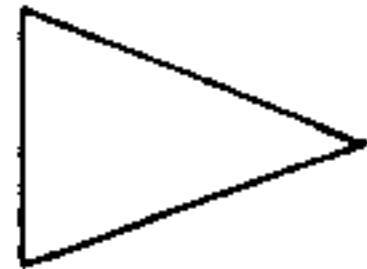

T1

Plate, grid, or cathode modulation; double sideband or SSB with carrier. Modulation less than 100%. No distortion.

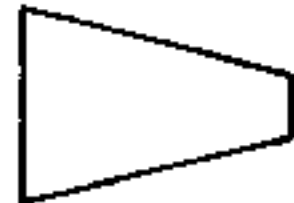

T2

Non linear. With plate modulation, indicates lack of grid drive. With grid modulation, SSB or DSB with carrier, or RF trapezoid through linear amplifier, indicates overdrive, insufficient antenna loading, or grid current curvature.



T3

Plate modulation in excess of 100% in downward direction.

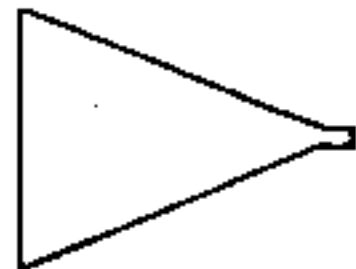

T4

Plate modulation, severely overmodulated. Good modulator capability.

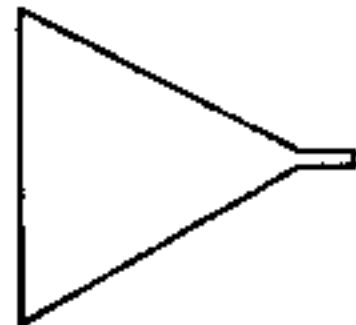
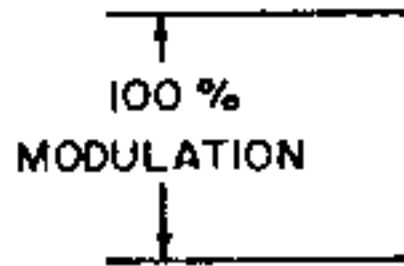

T5

Plate modulation. Audio phase shift due to improper audio connection. Modulated approximately 80%.



T6

Plate modulation. Overmodulation in downward direction, with insufficient modulator capability.

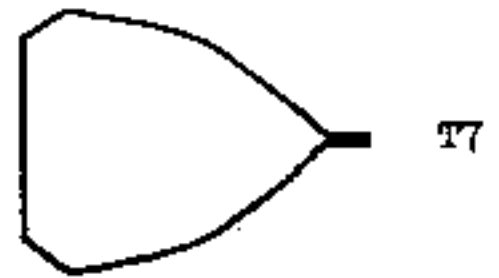
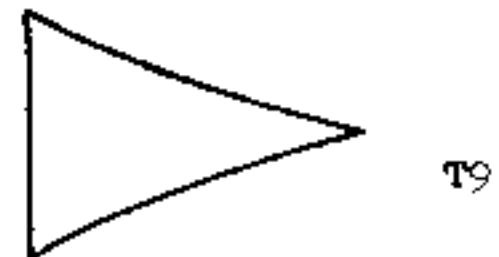

Plate modulation. Inadequate or mismatched modulator.



Non linear. With plate modulation this indicates regeneration due to improper neutralization. In linear operation this also indicates regeneration, or excessive grid bias.



Non linear. With plate modulation this is caused by insufficient driving power, or insufficient grid bias. In linear amplifiers this indicates regeneration or grid current curvature.

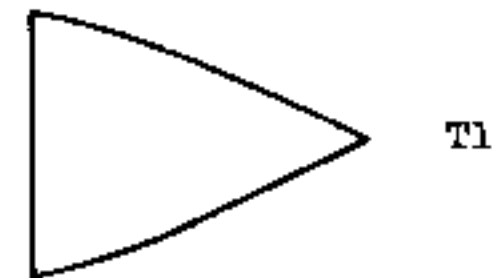

Positive peak parasitics.

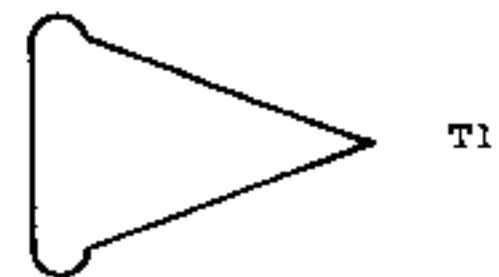

Screen grid or suppressor grid modulation, 100% modulated.

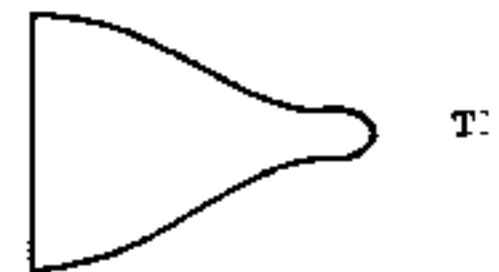

Grid modulation with improper neutralization and reactive load.



T13

Unmodulated carrier. Can be caused by:

No signal at Horizontal Deflection plates.  
1 kc. test oscillator inoperative.  
Gain control turned off on transmitter or oscilloscope.  
Audio failure in transmitter.



T14



## SERVICE INFORMATION

### WARNING!!

Potentials in the vicinity of 1000 volts exist both above and below the chassis and should be treated with proper caution.

Exercise care when handling the cathode ray tube. It may become scratched and weakened to the point where it is easily broken, which may result in injury from flying glass particles.

### REPAIRS

Under no circumstances should the instrument be returned to the factory without proper authorization and shipping instructions. In any correspondence with the factory concerning repairs, the serial number of the unit and a detailed description of the trouble must be given.

### 1KC AUDIO FREQUENCY OSCILLATOR ADJUSTMENT

A 12AT7 dual triode is employed as the audio frequency oscillator. Low distortion is obtained by adjusting the 5K feedback potentiometer R57 to the point where oscillation is just sustained.

### WARNING!!

If R57 is too far counterclockwise the output will be rich in harmonics, which will make an otherwise excellent SSB exciter appear to have poor sideband suppression on an oscilloscope pattern.

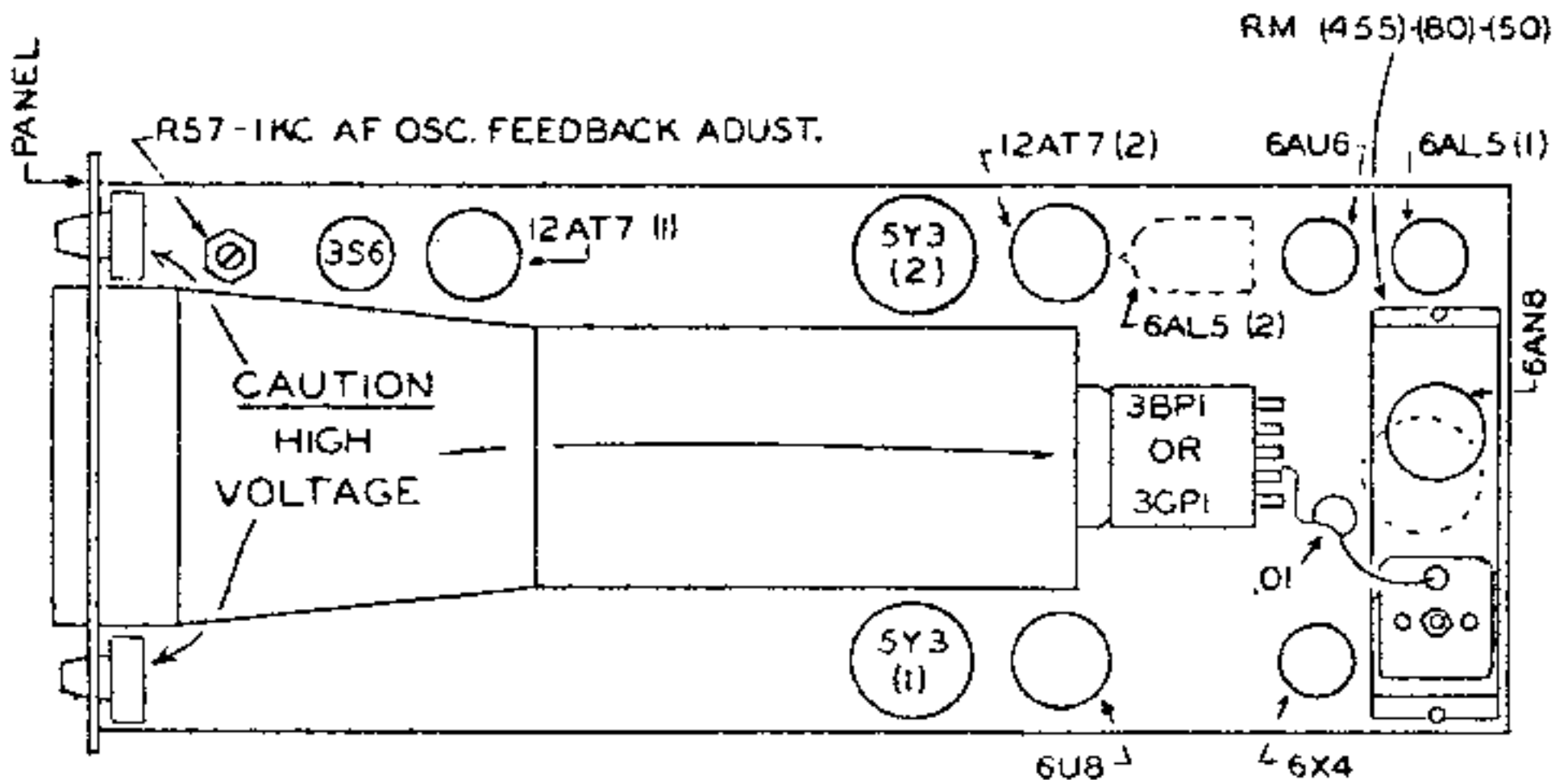

TUBE LOCATION CHART

### BLANKING BIAS ADJUSTMENT WITHOUT RM ADAPTER

Potentiometer R63 located on the large bracket underneath the chassis, has been adjusted at the factory on all wired units.

If the 6U8 keying tube is changed, or the MM-2 has been assembled from a kit, proceed as follows:

1. Put FUNCTION switch in the MANUAL position.
2. Adjust the INTENSITY control to approximately 90% clockwise rotation.
3. Move FUNCTION switch to SINE position and adjust Pot until blanking occurs.

If the automatic spot blanking circuit should fail to operate, the 6U8 tube should be changed immediately and the blanking bias readjusted.

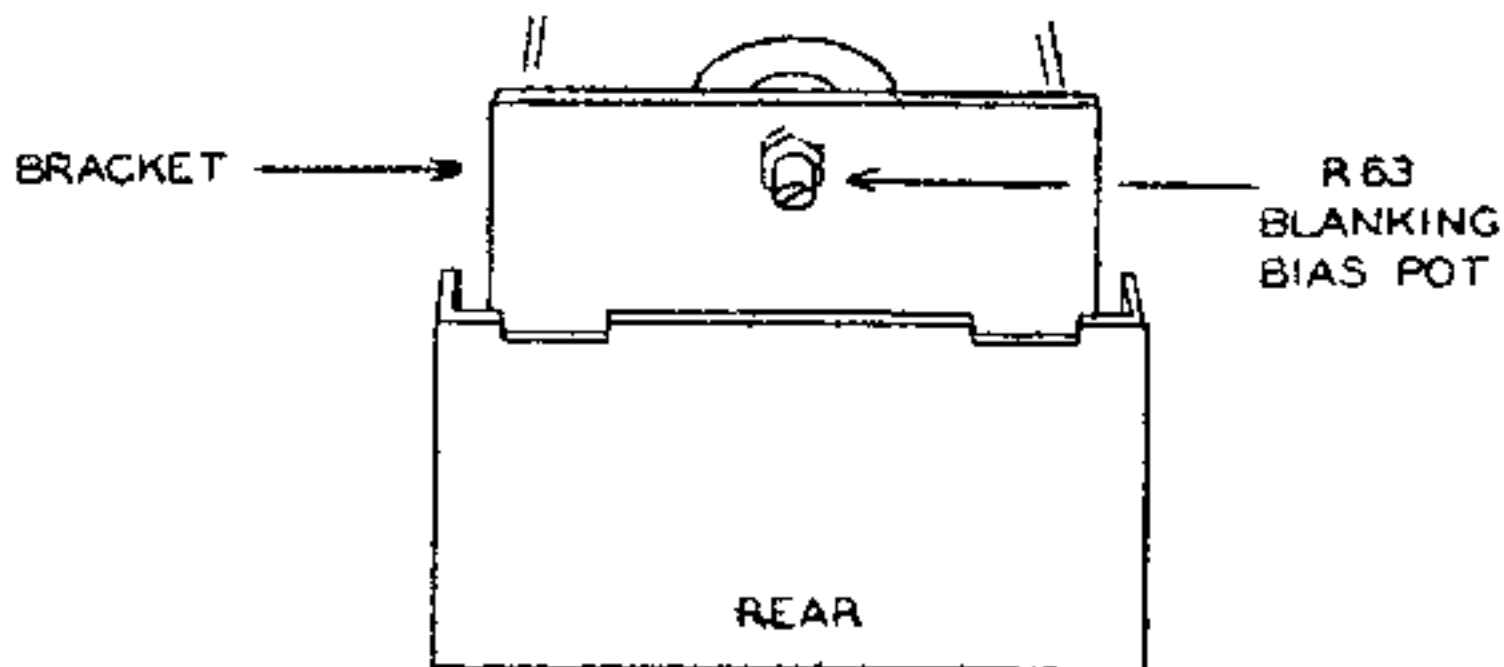

### OPERATION OF THE AUTOMATIC KEYING CIRCUIT

The RF INPUT signal is rectified in one half of the 6X4 Hi Level Rectifier. The positive DC output voltage is filtered and applied to the Pentode control grid of the 6U8 keying tube. This tube is a DC amplifier furnishing control voltage to the switching diode (6AL5) and to blank the CRT when used without RM adapter.

To adjust pot R63, first turn R63 fully clockwise, then measure voltage at the plates of the 6AL5 switching diode, while FUNCTION switch is in MANUAL (this will be about 8 to 10 volts negative on VTVM). Then change FUNCTION switch to SINE and adjust R63 to give the same reading on VTVM as in MANUAL position.

# MM-2 BLOCK DIAGRAM

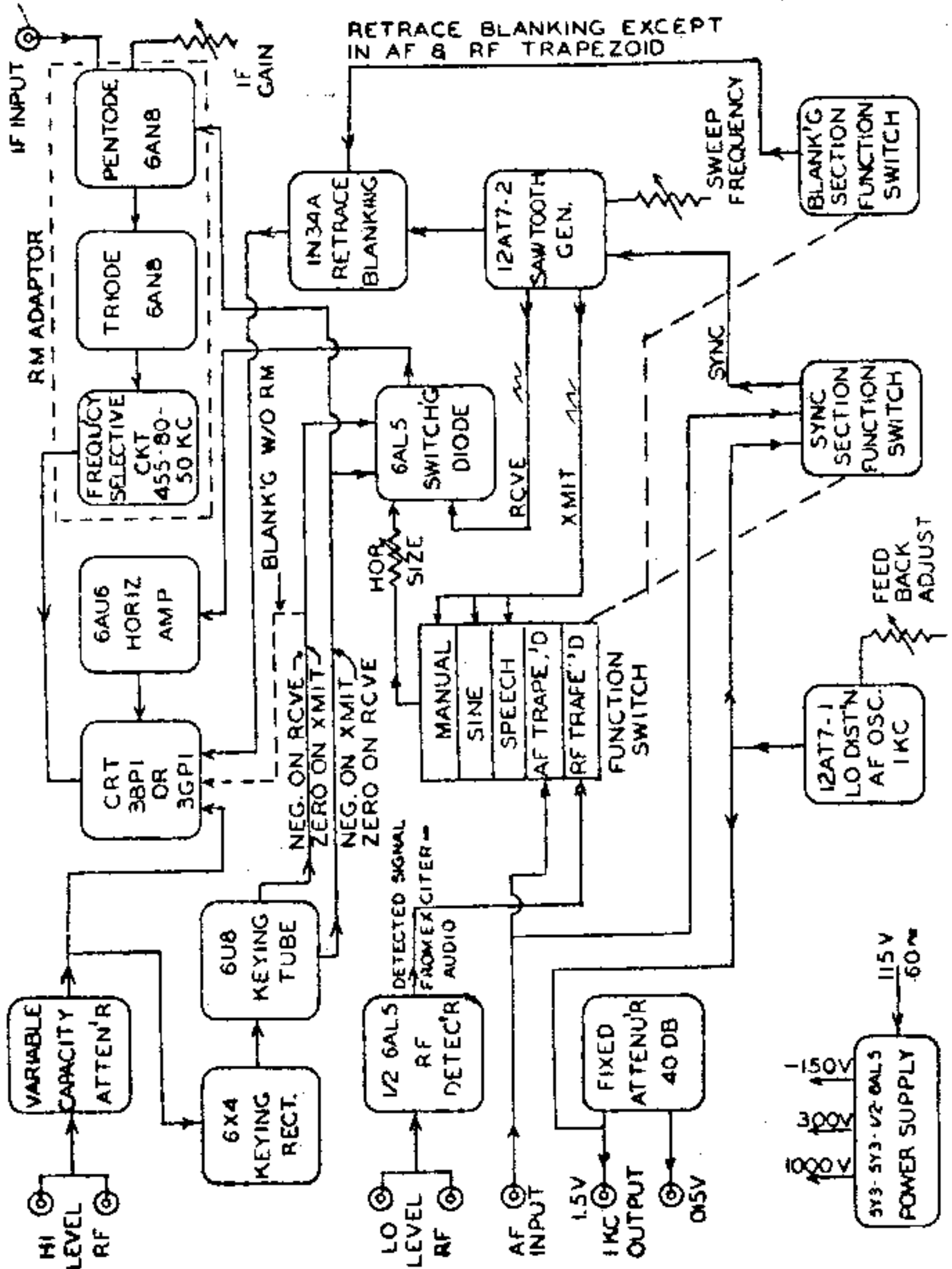



## MODEL MM-2

### BLANKING AND SWITCHING BIAS ADJUSTMENT

On all model MM-2 RF Analyzer serial numbers B750 and below, the blanking bias adjustment was set for use without the RM adapter. When the RM adapter is installed, R63, located on the bracket underneath the chassis as shown on page 22 should be turned completely clockwise.

All units serial number B751 and above have been adjusted for use with the RM adapter. If operation without the RM adapter is contemplated, with the Function switch in Manual, the Intensity control completely counterclockwise and no RF input, adjust R63 until the horizontal sweep line just disappears.

CENTRAL ELECTRONICS, INCORPORATED  
A SUBSIDIARY OF ZENITH RADIO CORPORATION  
1247 WEST BELMONT AVENUE  
CHICAGO 13, ILLINOIS

January 23, 1959

MM-2 CHANGE NOTICE

All tan colored wires are changed to red-brown.

All pink colored wires are changed to red-green.

All white-violet colored wires are changed to  
white-red-blue.

Please correct your circuit diagrams accordingly.

In units constructed from kits, these new colors  
will be supplied in lieu of the old ones.

CENTRAL ELECTRONICS, INC.  
1247 W. Belmont Avenue  
Chicago 13, Illinois

4/17/61

MM-2 NOTICE

This MM-2 has been adjusted for use with an RM Adapter.

If this unit is used without an RM adapter, be sure to adjust R63 as described in the manual to prevent the high intensity pattern from damaging the screen cathode ray tube.

Central Electronics, Inc.  
6/15/61  
MM-2 Wired

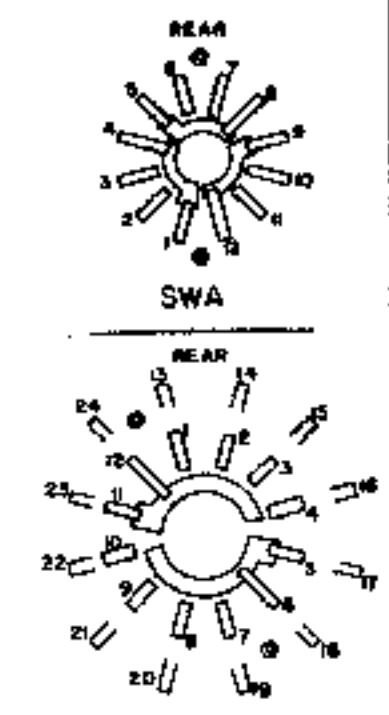
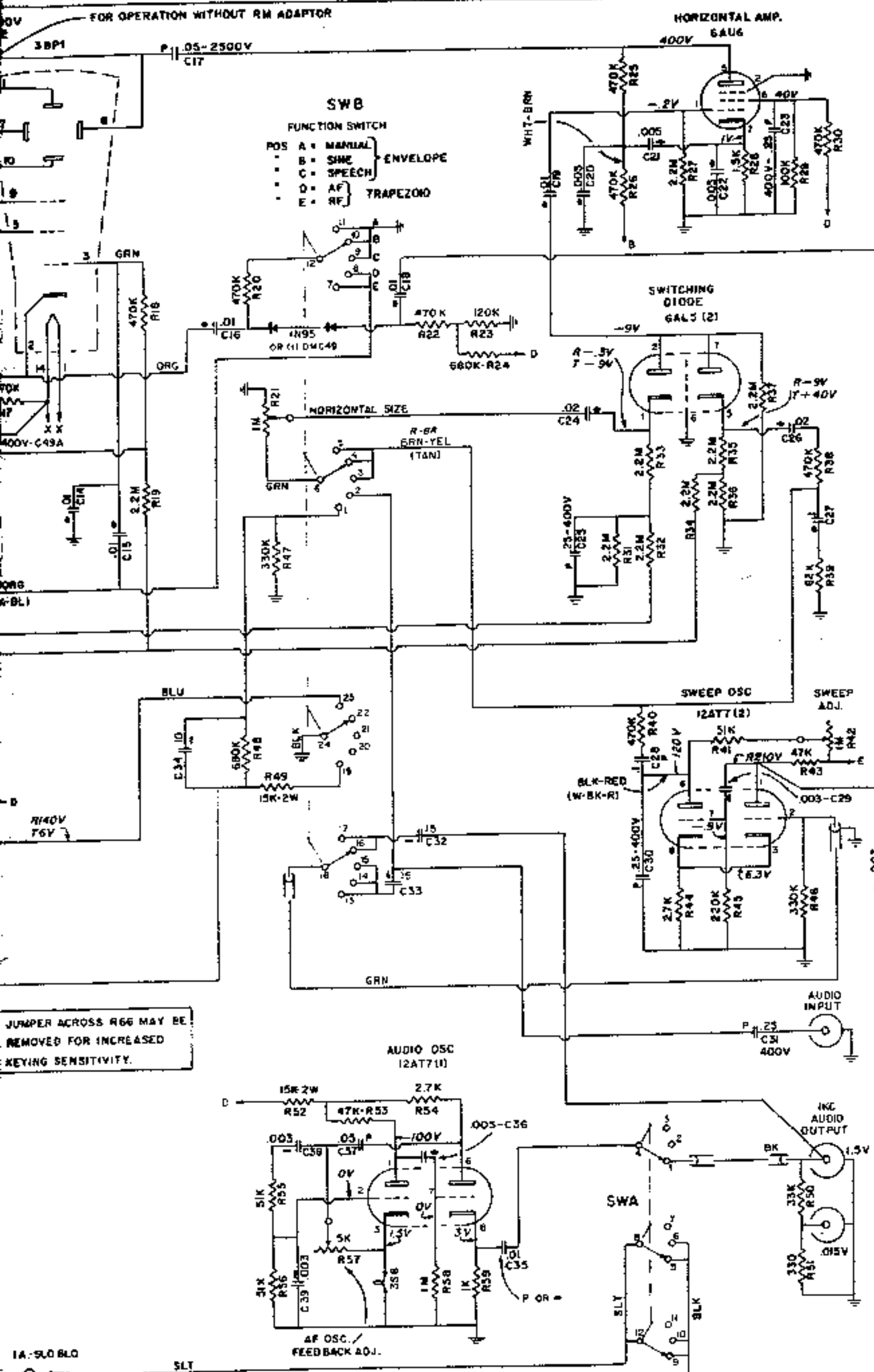

TERMINALS 13 TO 24 ARE ON WAFER NEXT TO BRACKET

RESISTORS ARE 1/2 WATT 10% EXCEPT AS NOTED  
 DECIMAL CAPACITOR VALUES ARE MFOS, OTHERS ARE MMFOS EXCEPT AS NOTED  
 P= TUBULAR PAPER CAPACITOR 600V, EXCEPT AS NOTED  
 E= ELECTROLYTIC CAPACITOR  
 C= CERAMIC  
 M= MICA  
 K= X 1000 M= X 1000000  
 ( ) = ALTERNATE WIRE COLOR ITALICS

ALL VOLTAGES MEASURED WITH VTVM. ALL AC VOLTAGES ARE RMS. SWITCH B IN SINE POSITION. IRC OSCILLATOR 'ON'.  
 R = WITH NO RF AT HI LEVEL INPUT.

T = WITH 12V CW RF INPUT, 1/2" HIGH PATTERN WITH JUMPER FROM HI LEVEL TO LO LEVEL COAX CONNECTORS.

CERAMIC CAPACITORS  
 .1MF = 100 V  
 .01" = 500V EXCEPT AS NOTED.  
 .02" = 500 V  
 .005" = 500 V

JUMPER ACROSS R66 MAY BE REMOVED FOR INCREASED KEYING SENSITIVITY.

FIG. 1

REV. 4-18-61. ALTERNATE WIRE COLORS ARE SHOWN IN ITALICS.
REV. 3-18-60
REV. 2-10-58
SCHEMATIC RF ANALYZER MODEL MM-2
CHKD BY
DRG NO 2211 10-15-57
CENTRAL ELECTRONICS, INC. 1247 BELMONT AVE. CHICAGO 13, ILL.



FOR OPERATION WITH RM ADAPTOR

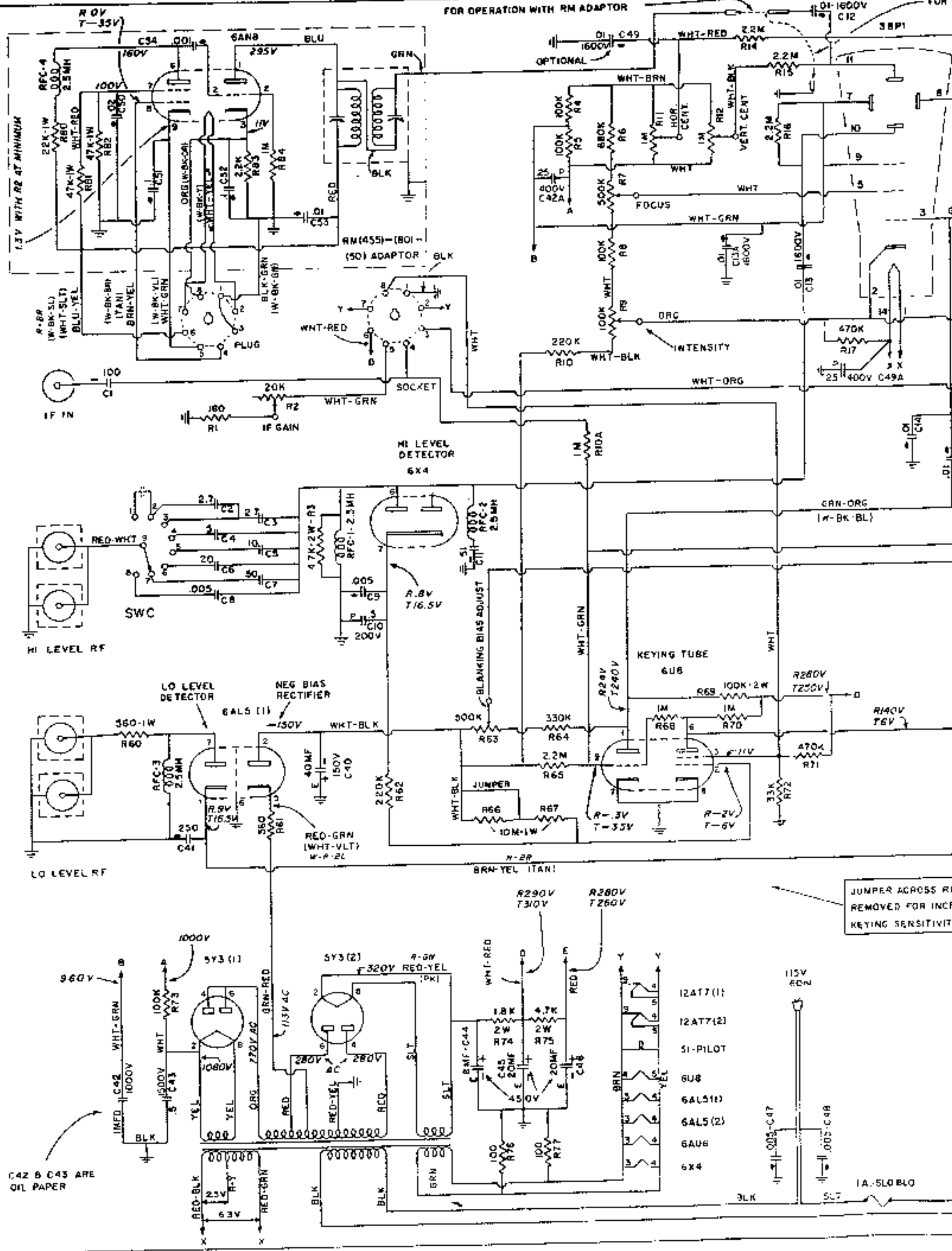

# **K4XL's** **BAMA**

This manual is provided **FREE OF CHARGE** from the "BoatAnchor Manual Archive" as a service to the Boatanchor community.

It was uploaded by someone who wanted to help you repair and maintain your equipment.

If you paid anyone other than BAMA for this manual, you paid someone who is making a profit from the free labor of others without asking their permission.

You may pass on copies of this manual to anyone who needs it. But do it without charge.

Thousands of files are available without charge from BAMA. Visit us at <http://bama.sbc.edu>